

**NL** Installatievoorschrift  
Inductiekookplaten

**GB** Installation instructions  
Induction hobs

**DE** Installationsanleitung  
Induktionskochfeld

**FR** Instructions d'installation  
Plaque de cuisson induction



Dit toestel mag alleen door een erkend installateur worden aangesloten. Lees de veiligheidsvoorschriften.  
The fitting of the appliance should only be carried out by a registered and qualified installer. Please read the safety regulations.  
Cet appareil ne peut être installé que par un technicien gazier agréé. Lisez les instructions de sécurité.  
Dieses Gerät darf nur von einem anerkannten Installateur angeschlossen werden! Bitte lesen Sie die Sicherheitsbestimmungen.

**Vorbereidingen voor montage/Preparations for installation**  
**Préparation avant installation/Vorbereitung der Montage**

Gebuurkte pictogrammen/Pictograms used  
Pictogrammes utilisés/Verwendete Piktogramme

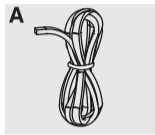

Belangrijk om te weten/Important information  
Important à savoir/Wichtig zu wissen



Elektrische aansluiting/Electrical connection  
Branchement électrique/Elektrische anschluss

Vrije ruimte rondom toestel  
Free space around appliance  
Espace libre autour de l'appareil  
Freier Raum rundum das Gerät

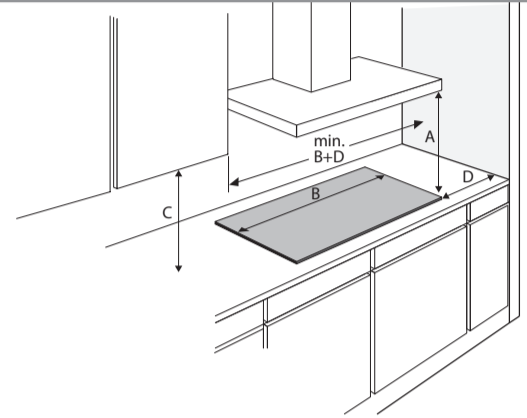

A (mm) C (mm) D (mm)  
min. 650 min. 450 min. 40



Dit toestel moet altijd geaard zijn.  
This appliance must be earthed.  
Cet appareil doit être mis à la terre.  
Dieses Gerät muß jederzeit geerdet sein.

De elektrische aansluiting moet voldoen aan de nationale en lokale voorschriften.  
The electrical connection must comply with national and local regulations.  
Le branchement électrique doit satisfaire aux prescriptions nationales et locales.  
Der elektrische Anschluß muß den nationalen und kommunalen Vorschriften entsprechen.

**Aansluitwaarden/Connected load/Charge connectée/Anschlussleistung**

	L1 (W)	L2 (W)	L3 (W)	Total load (W)
KIS670	3690	0	0	3690
KIF670	3600	3600	0	7200
KIF672	3700	3700	0	7400
KI680	3600	3600	0	7200
KIF680	3600	3600	0	7200

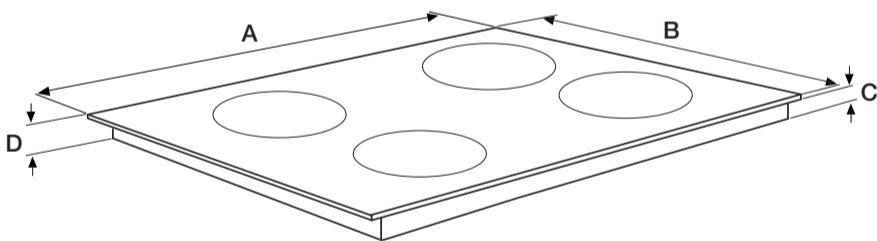

	A (mm)	B (mm)	C (mm)	D (mm)
KIS670	700	520	50	54
KIF670	700	520	50	54
KIF672	700	520	50	54
KI680	795	520	50	54
KIF680	795	520	50	54

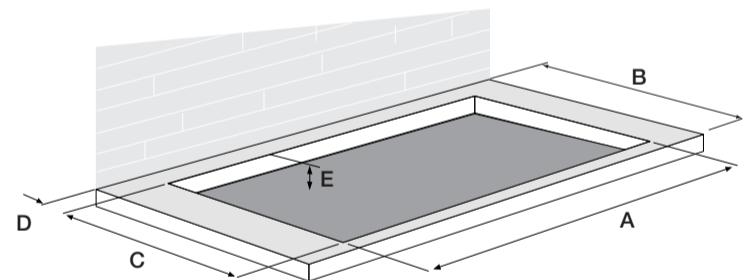

	A (mm)	B (mm)	C (mm)	D (>mm)	E (>mm)
KIS670	560	600	490	40	70
KIF670	560	600	490	40	70
KIF672	560	600	490	40	70
KI680	750	600	490	40	70
KIF680	750	600	490	40	70

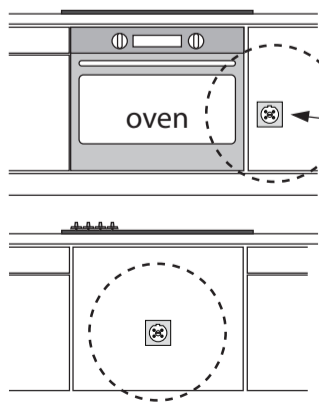

Bereikbaarheid!  
Accessibility!  
Accessibilité!  
Zugänglichkeit!

Afdichtband plaatsen/Placing sealing tape  
 Placement de la bande d'étanchéité/Abdichtband anbringen

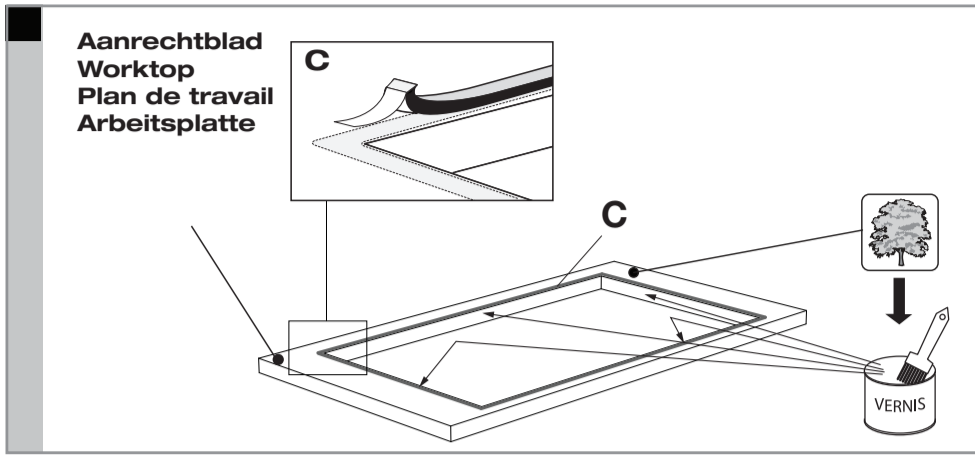

Elektrische aansluiting/Electrical connection  
 Branchement électrique/Elektrische anschluss

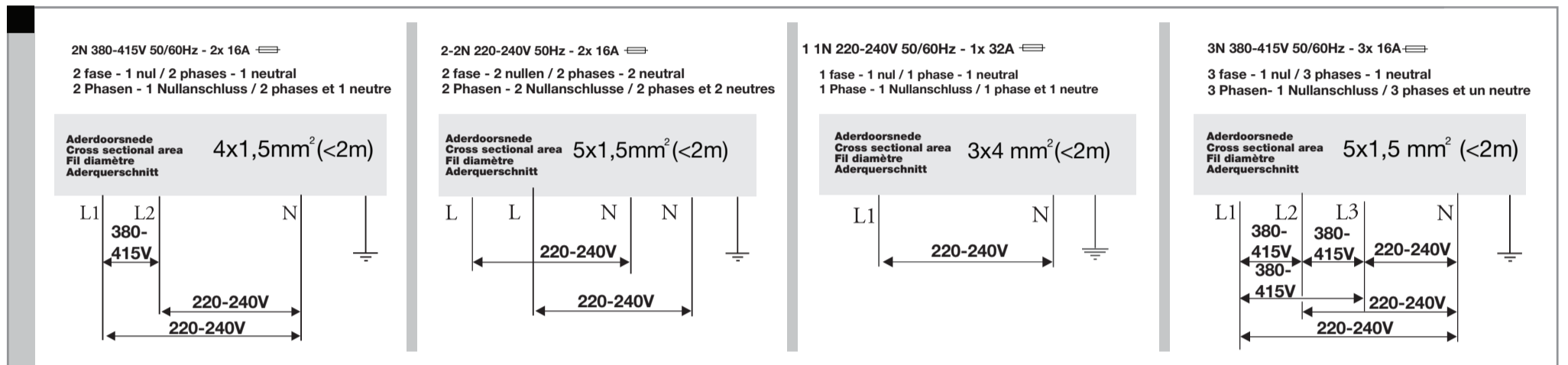

Raadpleeg de aansluitschema's op de achterzijde van het toestel/Maak de nodige doorverbindingen op het aansluitblok!  
 Consult the wiring diagrams on the back of the appliance/Make the required connections on the connecting block.  
 Consultez les schémas de raccordement situés derrière l'appareil/Effectuez les connexions nécessaires sur le bloc de raccordement !  
 Beachten Sie das Anschlussdiagramm auf der Rückseite des Geräts/Stellen Sie die erforderlichen Anschlussverbindungen am Anschlussblock her!

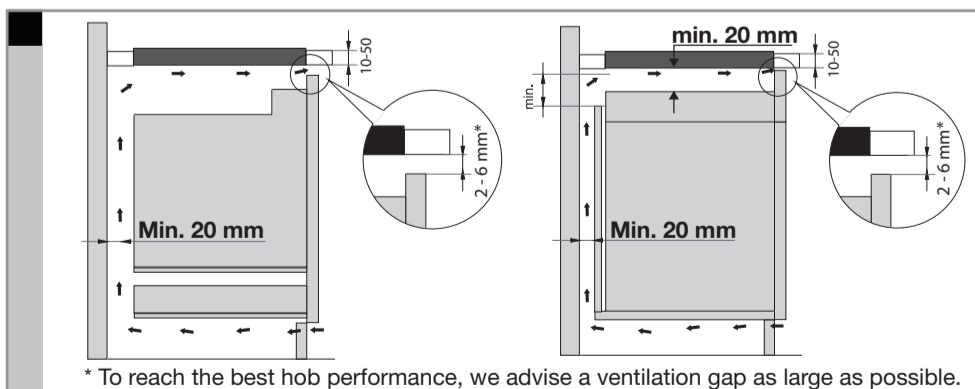
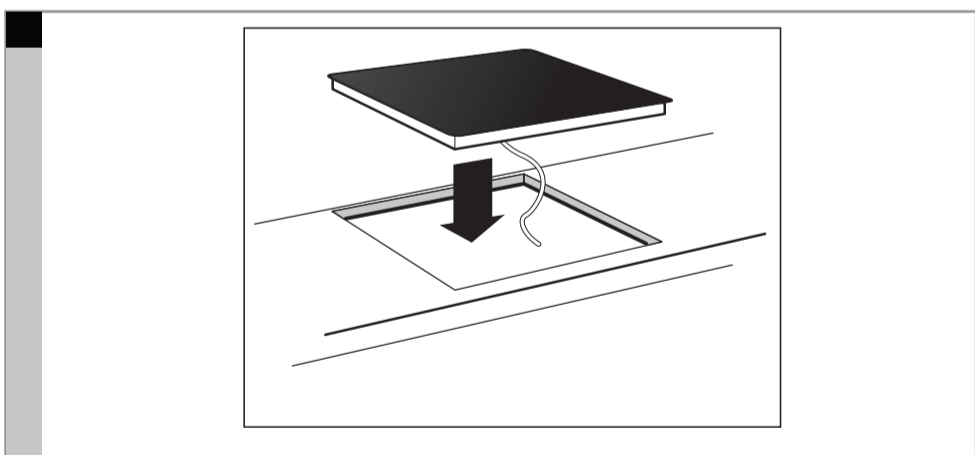
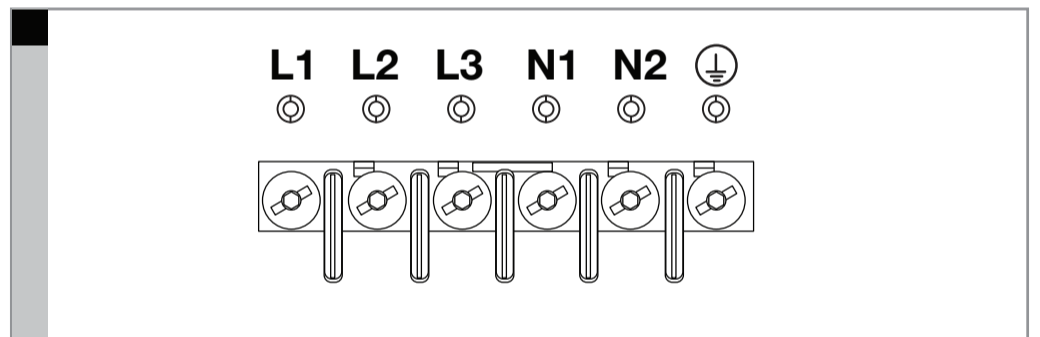
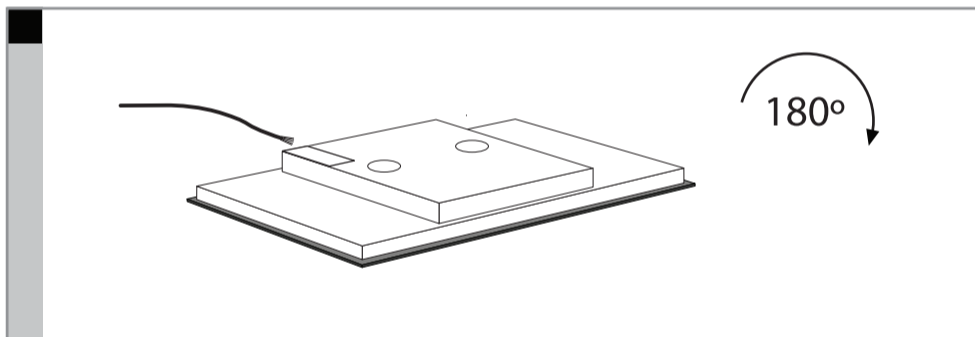

\* To reach the best hob performance, we advise a ventilation gap as large as possible.

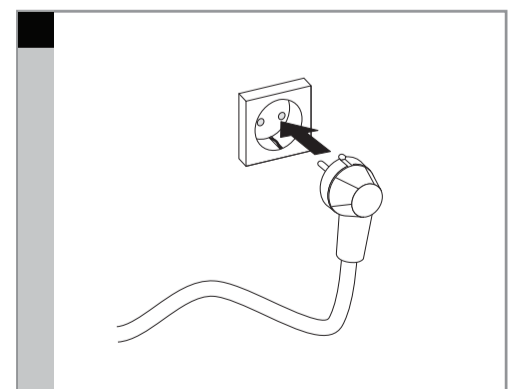
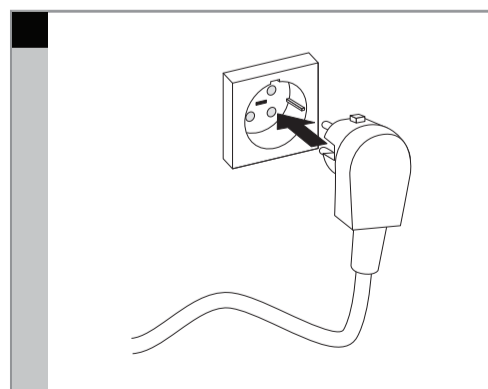

812129